

**Congratulations on the purchase of your Rinnai RHFE-952ER & RHFE-1252ER Flamefire.
We trust you will have many years of comfort and enjoyment from your appliance.**

**BEFORE PROCEEDING WITH THE OPERATION OR INSTALLATION OF YOUR NEW HEATER
PLEASE READ THIS MANUAL THOROUGHLY AND GAIN A FULL UNDERSTANDING OF THE
REQUIREMENTS, FEATURES AND OPERATION OF YOUR NEW APPLIANCE.**

OPERATION MANUAL

BEFORE YOU START.....	4
INSTALLATION REQUIREMENTS.....	4
CERTIFICATION	4
FLUE INSTALLATION MANUAL.....	4
CARTON CONTENTS / ITEM CHECKLIST.....	4
INSTALLATION RECORD.....	5
ABOUT RHFE-952ER / RHFE-1252ER SPACE HEATERS	6
GENERAL DESIGN LAYOUT	6
FEATURES.....	6
SAFETY.....	7
SAFETY DEVICES	9
CONTROL PANEL OPERATION	10
TO TURN YOUR HEATER ON	10
TO TURN YOUR HEATER OFF.....	10
INTERRUPTION TO ELECTRICITY OR GAS SUPPLY DURING OPERATION	10
RESTART PROCEDURE AFTER INTERRUPTION TO ELECTRICITY SUPPLY	10
FULL CONTROL AND PARTIAL CONTROL.....	10
REMOTE CONTROL OPERATION	11
BATTERIES AND ACTIVATING THE REMOTE CONTROL	11
BUTTON FUNCTIONS, DISPLAY & OPERATION	11
REPLACING THE CR2450 BUTTON BATTERIES	12
LOST, MISPLACED OR BROKEN REMOTE CONTROL	12
CARE AND MAINTENANCE	13
CLEANING	13
FILTERS	13
WARM AIR VENT.....	13
GENERAL HEATER CHARACTERISTICS	14
SERVICE	14
TROUBLE SHOOTING CHECKLIST	15
ABNORMAL FLAME PATTERN.....	15
ERROR CODES	16
INSTALLATION MANUAL	17
CONTACT INFORMATION	32

INSTALLATION RECORD

INSTALLERS / GAS FITTERS DETAILS

Installer Name: _____

Company Name: _____

Company Address: _____

Company Contact Details

Telephone: _____

Mobile Phone: _____

Certificate of Compliance / Certification Number: _____

Authorised Persons - Licence Number: _____

Installers Signature: _____

Installation Date: _____

APPLIANCE DETAILS

Model Number: _____

Serial Number: _____

Installation Address: _____



THIS APPLIANCE MUST BE INSTALLED, SERVICED AND REPAIRED ONLY BY AN AUTHORISED PERSON.

The mesh dress guard supplied with this appliance must not be permanently removed as it fulfils an operational safety function. Additional dress guards including free standing types may be used in conjunction with, but not replace, the dress guard supplied with this appliance.

ABOUT RHFE-952ER / RHFE-1252ER SPACE HEATERS

GENERAL DESIGN LAYOUT

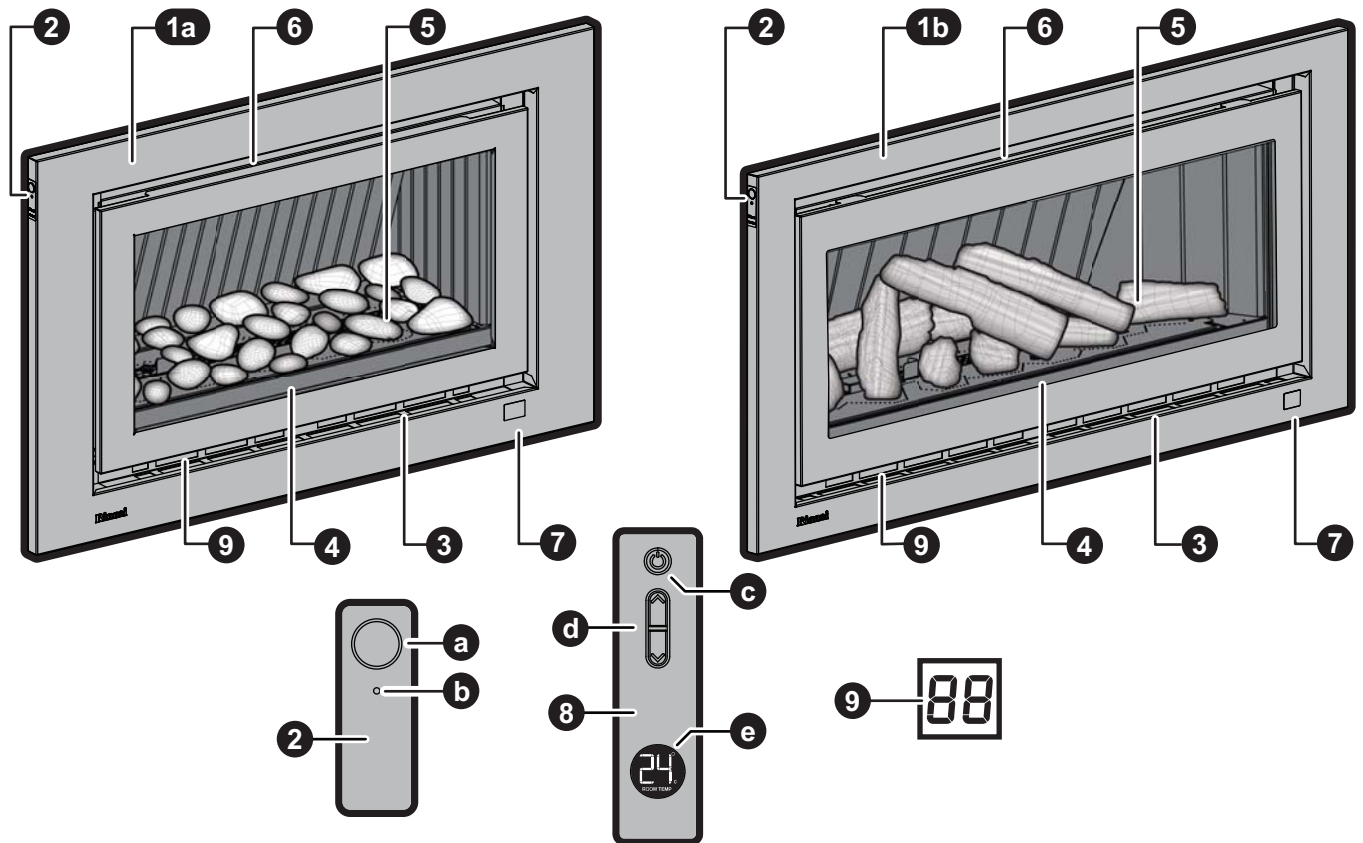

- 1a** Rinnai RHFE952ER - (shown with the ceramic stone set installed)
- 1b** Rinnai RHFE1252ER - (shown with the ceramic log set installed)
- 2** Appliance push button control panel
 - a** ON / OFF button
 - b** Standby Indicator (Red)
- 3** Room air return / Inlet filters - Dust filter meshing is fixed to the inlets of the room air return.
- 4** Glass flame window
- 5** Burner box - ceramic stone set / ceramic log set and burn media
- 6** Warm air discharge vent
- 7** Remote (IR) control receiver window
- 8** Remote (IR) control
 - c** Standby / ON button
 - d** Flame Up / Down buttons
 - e** Room temperature display (displays the current temperature of the room in which the control is located)
- 9** Viewing window for error code display (This is located behind the fascia, see page 15 for details)

FEATURES

- **Room Sealed:** Air for combustion is taken from the outside and the flue products are exhausted to the outside. This means heater operation has no effect on the composition and quality of air in the room.
- **Push Button Ignition:** Only one touch of the STANDBY/ON switch is all that is required to operate the heater.
- **Remote (IR) Control:** Infra Red remote for flame height adjustment with inbuilt room temperature display.

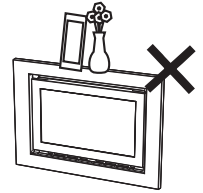
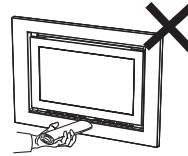
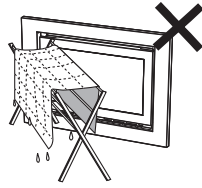
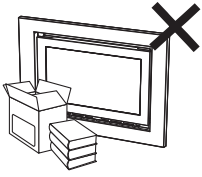

DO NOT restrict the warm air discharge by placing articles in front of the heater. This appliance must not be used for any purpose other than heating.

DO NOT allow anyone to post articles through the louvres or let flammable and combustible materials to come into contact with the heater.

DO NOT place articles on or against this appliance, on the heaters top panel or obstruct the auto overheat discharge vent.

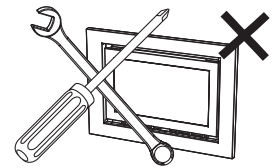
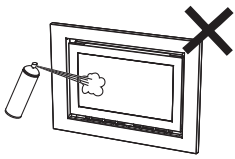

DO NOT spray aerosols in the vicinity of this appliance whilst the heater is operating. Most aerosols contain flammable gas, which can be a fire hazard if used near the heater when it is in use.

DO NOT store flammable materials near this appliance.

DO NOT modify this appliance.

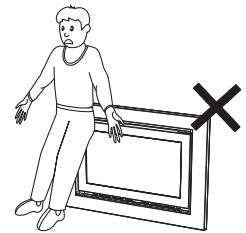
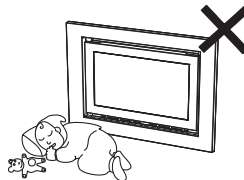
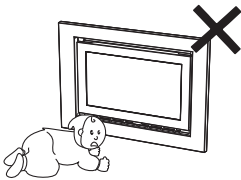

Young children should be supervised at all times. Hand or body contact with the warm air discharge louvres and glass must be avoided.

DO NOT allow young children or the infirm to sleep directly in front of the heater while in operation.

DO NOT allow anyone to sit on or lean against the appliance.

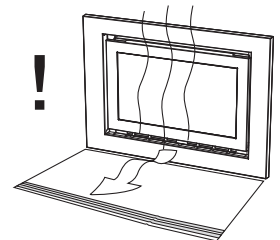
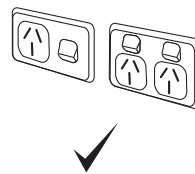
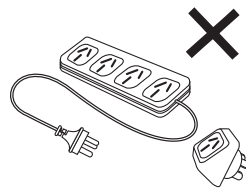
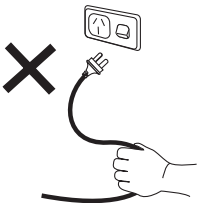

DO NOT unplug the heater while it is in operation or while the fans are still cycling. Unplugging the heater while in operation may cause the over-temperature switch to activate preventing the heater from restarting.

A dedicated 230~240V 50Hz 10 Amp power point must be used with this appliance. **DO NOT** use power boards or double adaptors to operate this appliance. The appliance **MUST NOT BE** located below a power point.

Heat emanating from the front of this appliance may over time affect the appearance of some materials used for flooring such as carpet, vinyl, cork or timber. This effect may be amplified if the air in the room contains cooking vapours or cigarette smoke. To avoid this possibility, it is recommended that a mat be placed in front of the appliance, extending at least 750 mm in front of it.

SAFETY DEVICES

Initial start-up: This heater has a one-time start up cycle. Should there be a fault in the heater no more than 3 manual restarts should be attempted. If the heater still fails to operate a service call will be required. Refer to the "CARE AND MAINTENANCE" pages; 13 through 15 for further information.

Over Heat Thermistor: Should the heater get too hot during operation, (for example when the air outlet louvres are blocked), this device will automatically turn the gas off and allow the heater to be manually restarted, (automatic re-start will not occur). Refer to the "CARE AND MAINTENANCE" pages; 13 through 15 for further information.

Over heat Thermal Fuse: In the unlikely event of the Over Heat Thermistor failing or some other fault occurring the Over Heat Thermal fuse will operate completely shutting the appliance down. This device is a 'one hit' only function, a service call will be required to reinstate operational ability to your heater. Refer to the "CARE AND MAINTENANCE" pages; 13 through 15 for further information.

Power Failure: Refer to page 10. In the event of power failure or power disruption your heater will shut down completely, manual restarting will be required. Refer to the "CARE AND MAINTENANCE" pages; 13 through 15 for further information.

Electric fuse: The electrical circuits are protected by a fuse. Refer to the "CARE AND MAINTENANCE" pages; 13 through 15 for further information.

Flame Failure Sensing System: These devices within the appliance automatically cut of the gas supply to the burners in the event of a flame failure. Refer to the "CARE AND MAINTENANCE" pages; 13 through 15 for further information.

Pressure Relief: The burner box glass panel is secured to the burner box via spring loaded pressure relief fasteners.

CONTROL PANEL OPERATION

TO TURN YOUR HEATER ON



BEFORE PROCEEDING ENSURE THE GAS AND ELECTRICITY ARE TURNED ON.

When the heater is in the OFF condition (the power supply connected and switched ON but the heater turned OFF) the Red Power Indicator **b** will be extinguished. This is normal.

Access the 'Push Button Control Panel' **2**. This is located on the top left hand side of the appliance.

Step 1. Press the ON / OFF button **a** once. You will be able to hear the ignition sparking.

Step 2. The sparking ignition stops when the pilot flame has been established.

The main burner then ignites off the pilot flame and is automatically preset to Stage 5 - High Flame.

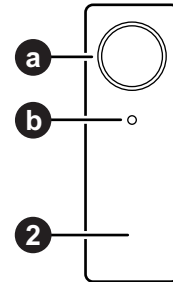

FLAME HEIGHT AND FAN SPEED

The relationship between flame height and fan speed is factory preset and cannot be adjusted.

Refer to "REMOTE CONTROL OPERATION" on the next page for Flame / Fan options.

Flame Height	1	2	3	4	5
Fan Speed (2 speed only)	Low	Low	Low	High	High

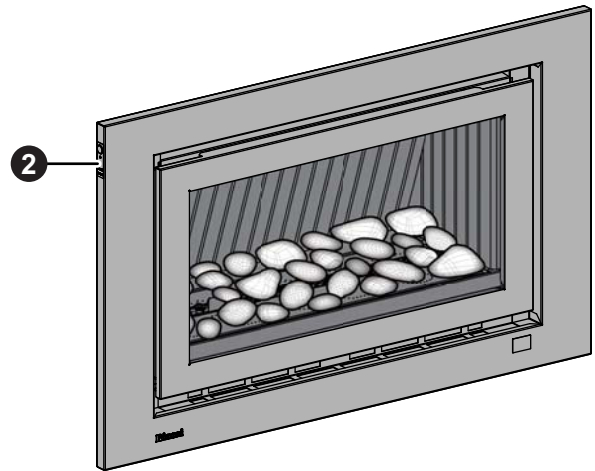

TO TURN YOUR HEATER OFF

To turn the heater 'OFF' press the 'ON'/'OFF' button **a** once, when the heater is in the off state the Red Power Indicator **b** will be extinguished.

INTERRUPTION TO ELECTRICITY OR GAS SUPPLY DURING OPERATION

Interruption to the power or gas supply will turn your heater off and a restart will be required. This is a safety feature designed to ensure that un-attended starts do not occur after power or gas interruptions.

RESTART PROCEDURE AFTER INTERRUPTION TO ELECTRICITY SUPPLY

To restart your heater once power has been restored follow the steps for "TO TURN YOUR HEATER ON" as above.

FULL CONTROL AND PARTIAL CONTROL

Full operation of the heater is only possible by using the remote control. In the event of a misplaced or broken remote control or if the batteries for the remote control are flat, this appliance may still be operated in a limited capacity by using the power ON/OFF button **a** of the 'Push Button Control Panel' **2** located on the top left hand side of the appliance.

The heater will automatically modulate between flame settings to maintain the default set temperature of 22°C.



No control of the flame or heat output is possible via the appliance ON/OFF button.

REMOTE CONTROL OPERATION



For the remote control to be able to function, the appliance ON/OFF button **a** must be in the "ON" position. Using the remote control to turn off the heater will place the heater into STANDBY mode, when in this mode the Red Power Indicator **b** will be on. This is normal.



WARNING KEEP BATTERIES OUT OF REACH OF CHILDREN.

- Swallowing may lead to serious injury in as little as 2 hours or death, due to chemical burns and potential perforation of the oesophagus.
- If you suspect your child has swallowed or inserted a button battery immediately call the 24-hour Poisons Information Centre on **13 11 26** for fast, expert advice.
- Examine devices and make sure the battery compartment is correctly secured, e.g. that the screws or other mechanical fasteners are tight. **DO NOT** use if compartment is not secure.



- Dispose of used button batteries immediately and safely. Flat batteries can still be dangerous and may be a choking hazard.
- Inform others about the risk associated with button batteries and how to keep their children safe.
- Remove the batteries if the remote is not going to be use for prolonged periods. This will help prevent damage from leaking batteries. If leakage has occurred and corrosion is evident the remote will need to be replaced.
- Leaking chemicals are toxic and **MUST NOT** be touched or ingested.
- NEVER** mix old and new batteries.
- DO NOT** immerse the remote control in any liquid, this will damage the remote control, rendering it inoperable and voiding its warranty.

BATTERIES AND ACTIVATING THE REMOTE CONTROL

- 2 x Button Batteries are supplied with the remote control.
- Remove the plastic tab to activate.
- This remote control uses 2 x Lithium CR2450 or equivalent batteries.
- The appliance will flash and emit 'Beeps' to confirm the setting has been received from the remote control unit; this indicates your remote control is now working.

BUTTON FUNCTIONS, DISPLAY & OPERATION

This remote control, **8** selects flame height and fan speed in five levels.

The STANDBY / ON button **c** switches the heater between the STANDBY and ON modes.

Flame height may only be adjusted after at least 30 seconds of operation.

The UP / DOWN buttons **d** control the height of the flame and heat output. The relationship between flame height and fan speed is factory preset and cannot be adjusted, there are five flame / fan settings as listed below.

Flame Height	1	2	3	4	5
Fan Speed <i>(2 speed only)</i>	Low	Low	Low	High	High

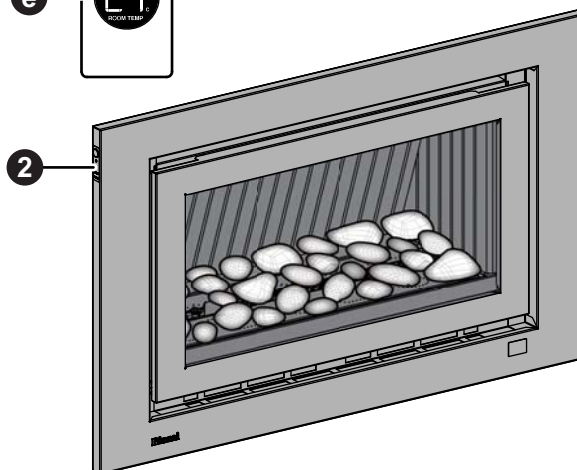
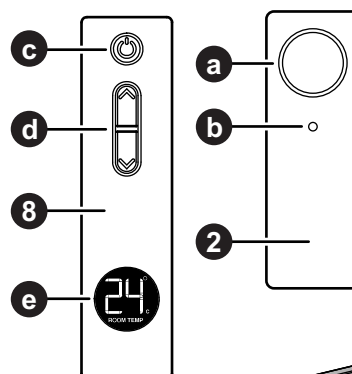

On initial start-up the appliance default flame height setting is setting 5 - High. Use the UP / DOWN buttons **d** to control the height of the flame / heat output.

The remote control temperature sensor (located on the base of the controller) reads the temperature of where the remote control is currently located.



The degrees Celsius room temperature display **e** has a motion activated back light which will remain illuminated for approximately 5 seconds after a movement is sensed or when a button is pressed. Frequent illumination of the back light greatly reduces the remote controls operational battery life, ensure that unnecessary illumination of the display is avoided.

REPLACING THE CR2450 BUTTON BATTERIES



When this low power symbol appears the batteries are near to being fully discharged and are unable to power the remote control properly. Replacement of batteries is now required.

1. Using a suitable lever remove the back cover by carefully prying off the back cover at the 6 pry points **f**.

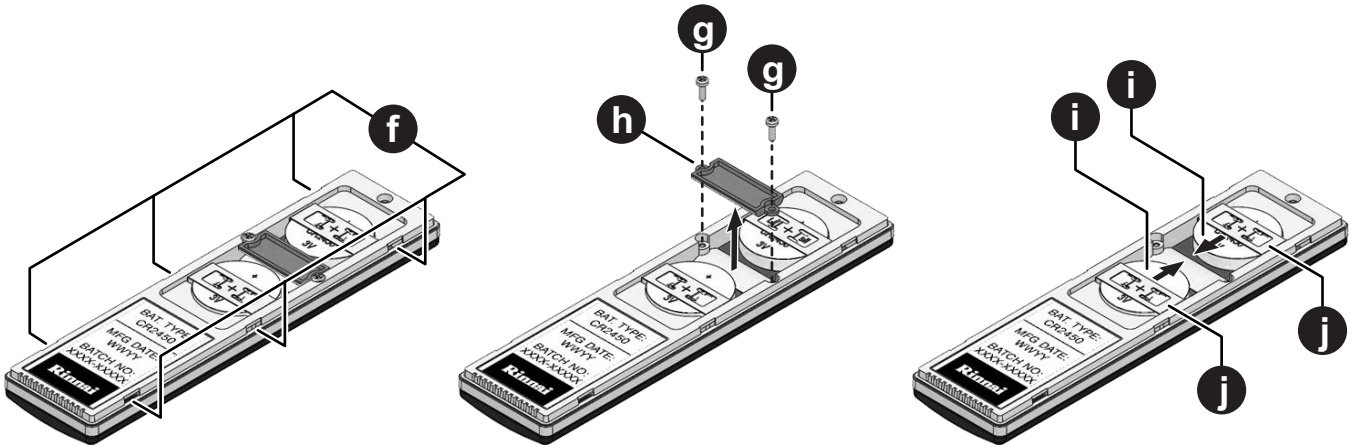

Note: Remote control is shown with back cover removed for illustrative purposes

2. Remove the two bridge retaining screws, **g** using a small (No.0) Phillips head screw driver or equivalent.
3. Remove the bridge **h**.
4. Remove the old batteries **i** by carefully sliding them out from under the retainers **j**, and into the space that was created when the bridge **h** was removed in step 3.
5. Insert two new batteries **i** (CR2450), ensuring the positive “+” terminals are facing up.
6. Reassemble the bridge in reverse order as per steps 2 & 3 above.
7. Re-attach the rear cover by carefully clipping it back into place.

LOST, MISPLACED OR BROKEN REMOTE CONTROL

In the event of a lost, misplaced or broken remote control the appliance may still be operated in a limited capacity. By using the manual control panel, **2** power ON/OFF button **a**, located on the top left hand side of the heater.

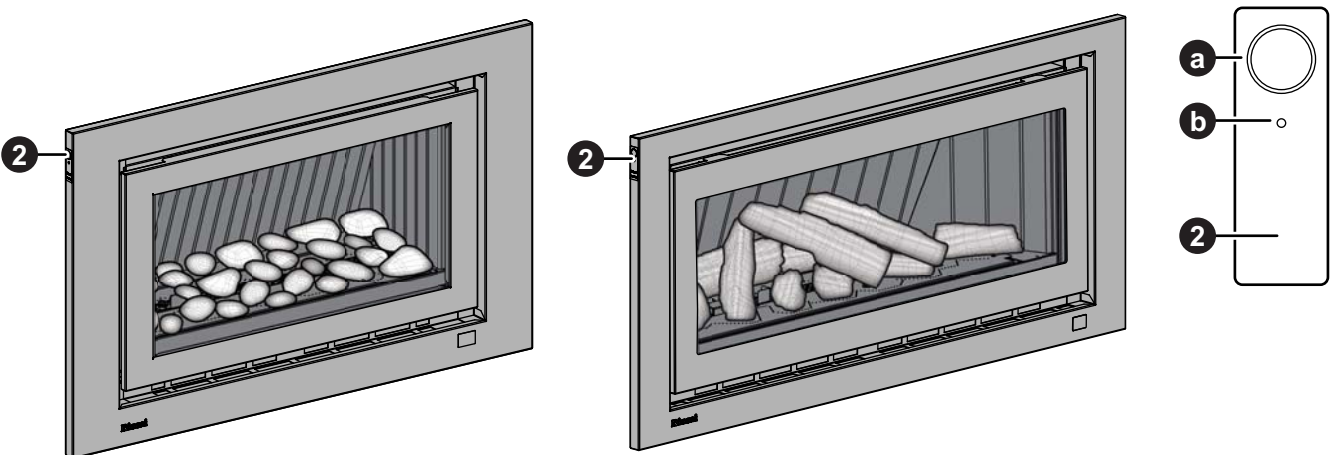

The heater will automatically modulate between flame settings to maintain the default set temperature of 22°C.



No control of the flame or heat output is possible via the appliance ON/OFF button.

CARE AND MAINTENANCE

CLEANING

Your heater needs very little maintenance, but the following information will help you to keep it looking good and working efficiently.



DO NOT attempt to clean the heater while the appliance is hot or operating.

All parts of the heater can be cleaned using a soft, damp cloth.

DO NOT use solvents or abrasives to clean any parts.

DO NOT spray aerosols in the vicinity of the heater whilst in operation.

DO NOT place any articles on or against this heater.

DO NOT store flammable materials near this heater.

FILTERS

The filter meshing for this appliance is fixed to the inlets of the room air return **3**.

The build up of dust or other particles on these filter strips reduces the air flow through to the heater which in turn reduces heater's efficiency and can lead to the appliance shutting down.

Filter Care

Filters require cleaning regularly during the heating season to prevent these unnecessary cut-outs.

Cleaning filter strips:

Clean any dust and other debris from both faces of the filters with either a vacuum cleaner, a soft dry cloth or a soft brush. **NEVER** attempt to clean filters with water.

Heater shut down due to filter blockages

DO NOT wait for the Filter Blockage Indicator to come on before cleaning filters.

DO NOT continue to use the heater once this Indicator is flashing.

When an obstructive build up is detected the Blockage Indicator LED which is located above the Receiver Window **7** will begin to flash RED to let you know that there is a problem.

Once the Indicator is flashing if no action is taken the heater will eventually shut down to avoid overheating and a fault code of 14 will be displayed in the Error Display **9** window.

Returning the appliance to normal operation after a shut down

To restore to normal operation after a filter blockage shut down do the following:

1. Access the 'Push Button Control Panel' **2**. This is located on the front of the heater at the lower right hand corner.
2. Press the On/Off **a** button once to turn off the heater.
3. Remove obstruction (see "Filter Care" on page 13).
4. Press the On/Off **a** button once to turn the heater back on.
5. Use the remote control to resume normal heater operation.

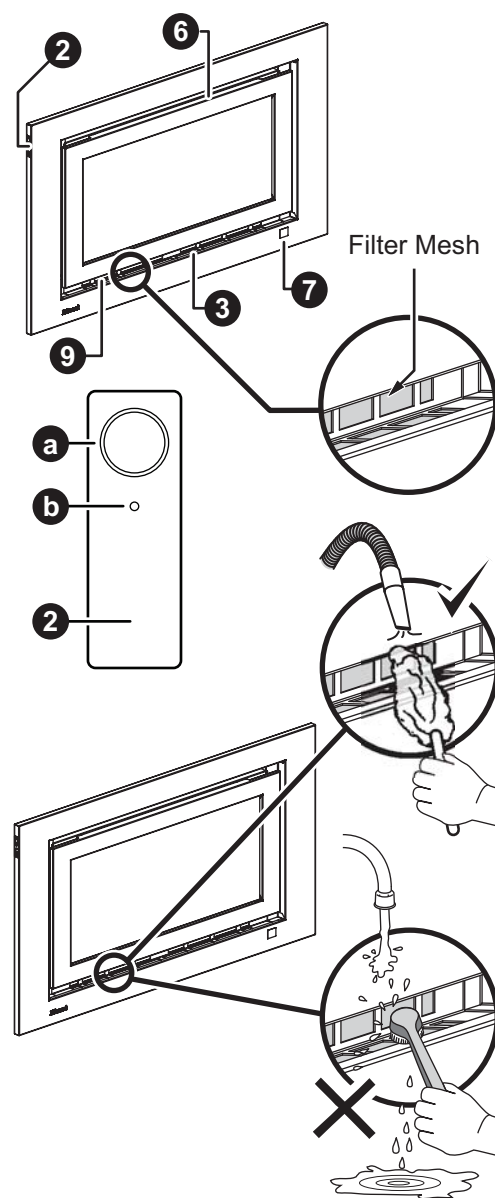

WARM AIR VENT

It is important that the Warm Air Discharge Vent **6** be kept clear of any obstructions as this will cause your heater to operate less efficiently. When an obstruction is detected the Blockage Indicator LED which is located next to the Receiver Window **7** will illuminate RED and the combustion state reduces to front burner, low operation only.

Removing the obstruction will allow normal heater operation to be resumed.

GENERAL HEATER CHARACTERISTICS

Before asking for a service call please check the following table as these characteristics are part of the normal operation of the appliance and do not indicate a fault.

CHARACTERISTIC	→	EXPLANATION
At ignition:		
Warm air does not start when the burner lights.	→	The room air fan is started automatically after a short delay. This is to allow the heat exchanger to warm up, helping to avoid cold draughts.
Smoke or strange smells are produced on the first start up operation after installation.	→	This is caused by grease, oil or dust on the heat exchanger when new. This will stop after a short time.
Sharp clicking sparking noises at ignition.	→	This is the electronic ignition sparking.
Ticking or pings when the unit thermostat modulates to a lower or higher setting, or shuts down.	→	This is simply expansion and contraction noise from the heat exchanger and is normal.
During combustion:		
Clunking noise when the thermostat operates	→	This is the sound of the solenoid gas valves opening and closing to regulate the gas flow and is normal.
When the appliance is turned off:		
Convection fan continues to run after turning off.	→	This is to remove residual heat from the heat exchanger and stops once the appliance cools.
Other points:		
Steam is discharging from the flue terminal.	→	High efficiency appliances tend to discharge water vapour on cold days. This is normal.
Heater does not start when the STANDBY / ON button is pushed, thermostat is on High (H).	→	Check that the appliance ON/OFF button is ON.

SERVICE

Rinnai recommend that this appliance and installation be inspected and serviced every 2 years.

If the power supply cord or any other component of the heater are damaged, they must be replaced by Rinnai or a suitably qualified person.

Any service or repair work should only be carried out by an authorised person. Rinnai has service and spare parts departments nationally, see back cover for contact details.



Service calls for general cleaning, maintenance and wear and tear are not necessarily covered under the warranty. Service calls of this nature may be chargeable.

Faults caused by insufficient gas supply, gas quality, installation errors or operation errors are not covered by the Rinnai warranty. Refer to separate warranty booklet.

Appliances incorporating a live fuel effect and designed to operate with luminous flames may exhibit slight carbon deposition on burner media. Slight deposition is acceptable.

TROUBLE SHOOTING CHECKLIST

Use the following chart to help determine whether a service call is required, however if you are unsure about the way your heater is operating, contact Rinnai or your local agent.

ABNORMAL FLAME PATTERN

Each Rinnai Gas Fire has a distinct flame pattern. The flame should look the same every time you start your heater after an initial warm up period of approximately 15 minutes.

Fault Condition	Probable Cause							Possible Remedy
		No Display on remote	No ignition or control	Burners fail to ignite	Combustion stops	Smell of gas	Remote control	
Not plugged in or turned off.			●	●			●	Plug in power cord or press On/Off (7) button.
Mains power failure.			●	●	●			Use power failure reset procedure.
(Initial Install) Air in gas pipe.				●				Installer to purge air from gas supply.
Inlet mesh obstructed					●			Clean the inlet mesh.
Gas leakage.						●		Isolate gas supply, call Rinnai service, contacts on back page.
Gas supply turned off.				●	●			Turn gas supply on at the meter or cylinder.
Flat batteries.		●						Replace remote control batteries 2 x CR2450.

Abnormal flame performance and/or pattern can indicate a problem with your heater, such as blocked gas injectors, incorrectly installed / inadequate flue system or the Ceramic logs / stones and or burner media may have shifted from when the heater was first installed.

There are some warning signs that could indicate a problem. If any of the signs below occur, please contact Rinnai.

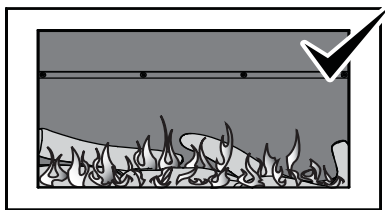

NORMAL FLAME PATTERN

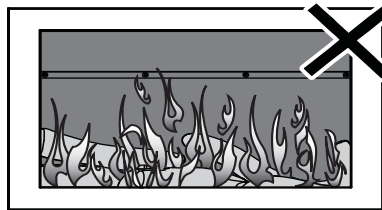

ABNORMAL FLAME PATTERN
CANDLING FLAMES

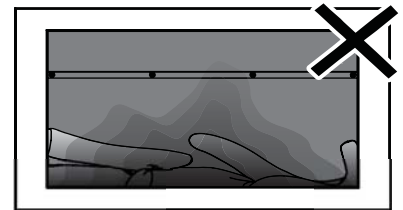

SOOT BUILD UP

Key signs of Abnormal flame performance:

- Appliance turns 'OFF' soon after start up and does not relight.
- Flame appears overly orange-yellow.
- Flame appears either very short or very long.
- Flame only burns part way across the burner.
- Severe soot building up on the inside of the glass and logs.
- Continuous unusual smell from the appliance.
- Continued difficulty or delay in establishing a flame.



Be advised that appliances incorporating a live fuel effect, and designed to operate with luminous flames, may exhibit slight carbon deposition, this is normal operation.

NOTE

ERROR CODES



In all cases, you should be able to clear the Error Code on display simply by turning the heater 'OFF', then 'ON' again. If the Error Message still remains or returns on the next operation, contact Rinnai or your nearest service agent and arrange for a service call.

Your Rinnai appliance is also fitted with self diagnostic electronics that monitor the appliance during start-up and operation.

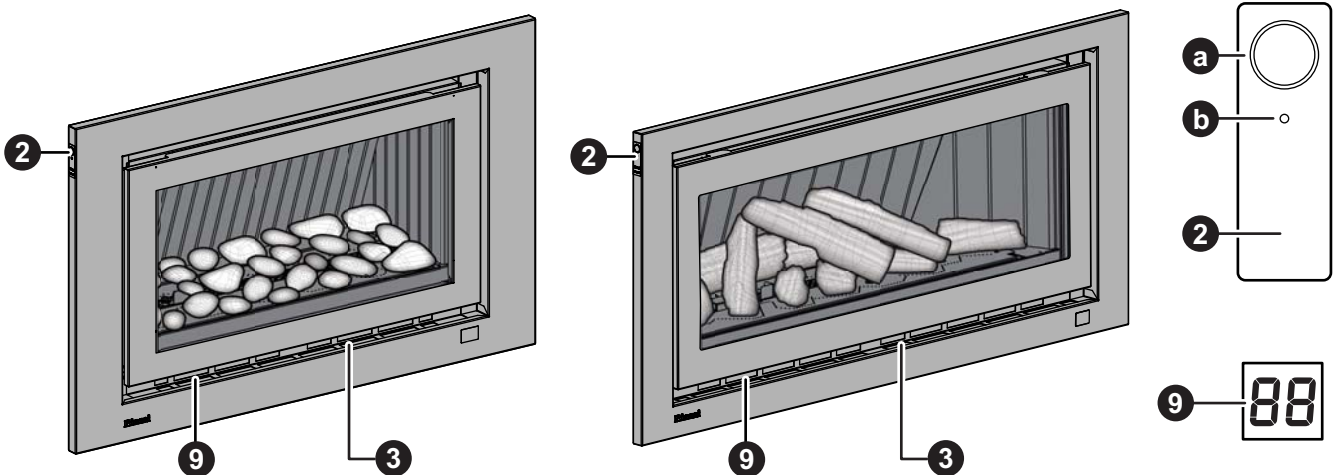

Should a fault occur the appliance will then shut down, the fault that has caused the shut down will be indicated by a pair of flashing digits in the error display window **9**, which is located behind the fascia and can be viewed by looking through the of the return air vent **3**.

Refer to the table below for probable cause and the suggested remedy.

Code	Probable Cause	Suggested Remedy
00	Mains power failure	Interruption to the power or gas supply will turn your heater off and a restart will be required. This is a safety feature designed to ensure that un-attended starts do not occur after power or gas interruptions. Access the 'Push Button Control Panel' 2 . This is located on the front of the heater at the lower right hand corner. Press ON / OFF button a twice, after which you will be able to hear the ignition sparking and the heater will restart and return to normal operation, after 30 seconds of operation the remote control may then be used to select the desired flame height and fan speed.
11	Ignition failure	Check gas supply is turned on, switch the heater to Standby and then On again. If the error persists a service call will be required.
12	Incomplete combustion	Check gas supply is turned on, switch the heater to Standby and then On again. If the error persists contact Rinnai.
14	Inlet Blockage / Overheat	Clean inlets, if the error persists a service call will be required.
16	Room overheat	Lower room temp to below 40°C.
31	Room temperature sensor faulty	A service call will be required.
32	Overheat temperature sensor faulty	A service call will be required.
33	Overheat temperature sensor faulty	A service call will be required.
53	Spark sensor faulty	A service call will be required.
61	Combustion fan motor faulty	A service call will be required.
71	Solenoids faulty	A service call will be required.
72	Flame detection circuit fault	A service call will be required.
73	Communication error	A service call will be required.

INSTALLATION MANUAL

OPERATION MANUAL	3
INSTALLATION GENERAL	18
PRODUCT SPECIFICATIONS	18
APPLIANCE DIMENSIONS	18
HEATER LOCATION	19
ENCLOSURE REQUIREMENTS	19
WALL PENETRATION REQUIREMENTS	19
GAS SUPPLY	20
ELECTRICAL SUPPLY	20
MANTLE INSTALLATIONS	20
FLUE INSTALLATION	21
TYPES OF FLUE INSTALLATIONS	21
FLUE SYSTEM TRANSITION CASTING	21
FLUE TERMINAL LOCATION	22
HEATER INSTALLATION	23
1. UNPACKING THE APPLIANCE	23
2. CONNECTING THE FLUE SYSTEM	23
3. SECURING THE ENGINE	24
4. CONNECTING THE APPLIANCE TO THE GAS SUPPLY	24
5. INSTALLING CERAMIC BURNER MEDIA	24
6. COMMISSIONING	28
7. INSTALLING THE OUTER FASCIA PANEL	28
8. INSTALLING THE INNER FASCIA PANEL	28
9. INSTALLATION AND COMMISSIONING CHECKLIST	29
10. FINAL CHECKLIST	29
WIRING DIAGRAM	30
CONTACT INFORMATION	32

A. Installation of Ceramic Log Set (RHFE-1252ER)

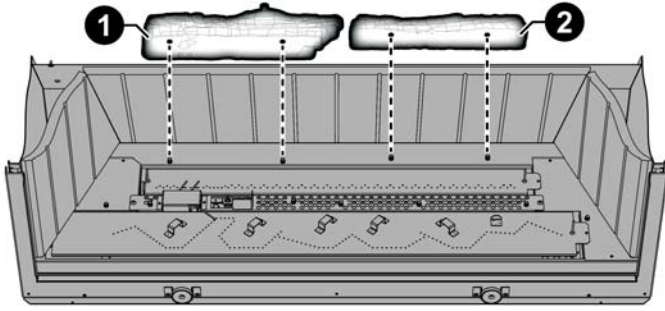

1. Logs **1** & **2** have a pair of pin holes in their bases, log **1** has an additional location pin on its top. Fit these logs to the back of the burner box as shown.

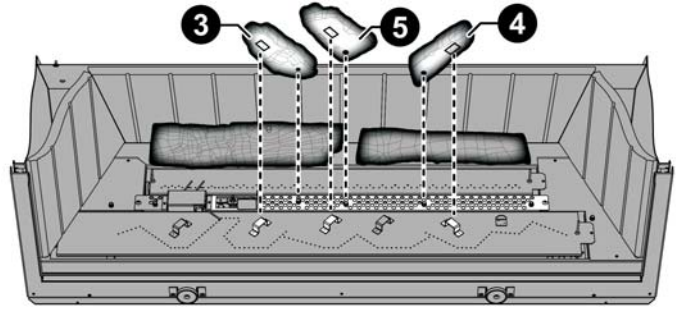

2. Logs **3**, **4** & **5** each have both a pin hole and a slot in their base and are dimensioned as to only fit in a specific location. Fit these logs to the front of the burner box as shown.

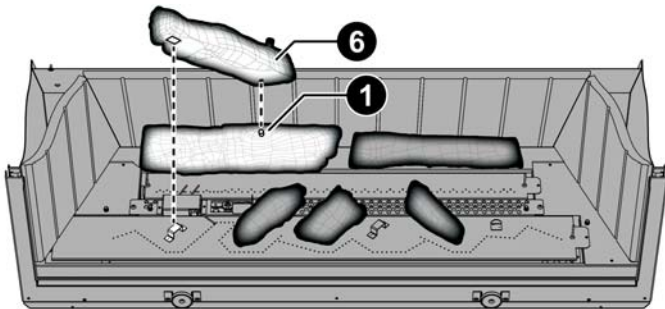

3. Log **6** has both a pin hole and a slot in its base and a location pin at one end on its top. Fit the log to front of the burner box and onto the pin of log **1** as shown.

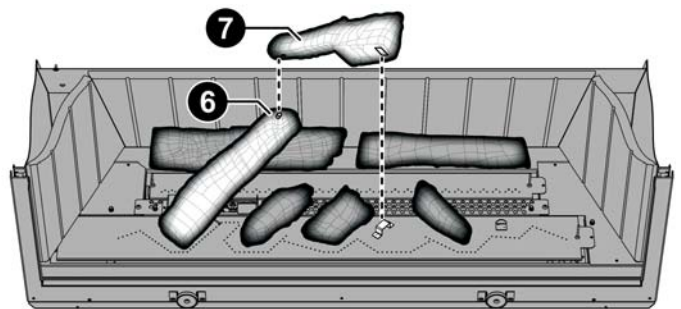

4. Log **7** has both a pin hole and a slot in its base and a location pin midway on its top. Fit the log to front of the burner box and onto the pin of log **6** as shown.

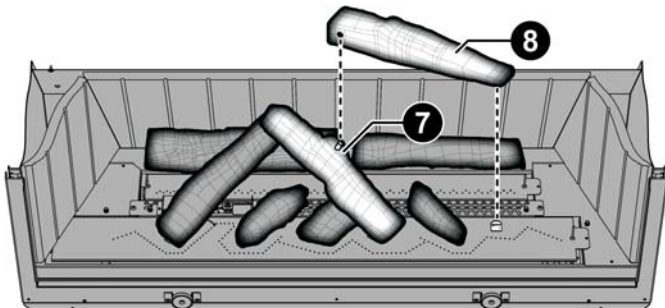

5. Log **8** only has a pin hole in one end of its base. Fit the log to slot in the middle of the burner box and onto the pin of log **7** as shown.

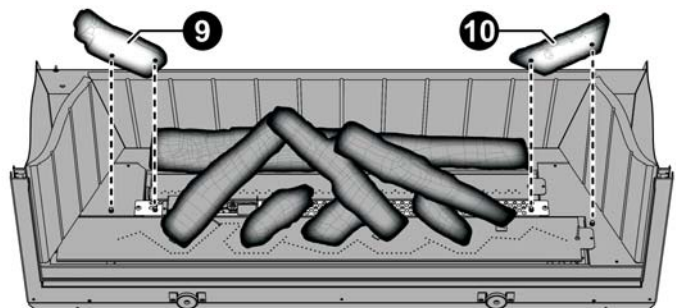

6. Logs **9** & **10** each have two pin holes in their base and are dimensioned as to only fit in a specific location. Fit these logs to the middle of the burner box as shown.

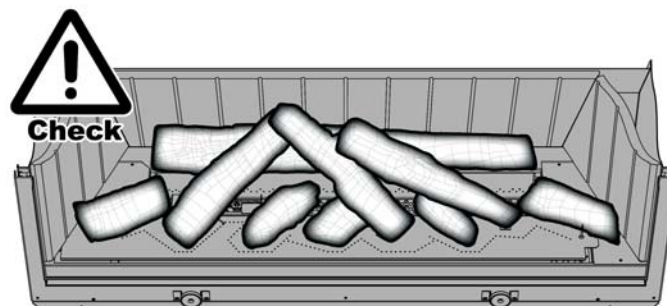

7. **⚠** Confirm the correct location of all the logs before proceeding with the placement of the granular burner medium.

Installation of Granular Burner Media (Both Models)

1. Ensure that all the logs are firmly seated in their correct positions and check that the ports of both burners are clean and clear of blockages from debris that may have been deposited during the log installation.
2. Carefully place the supplied granular burner media over and around the front and rear burner ports.

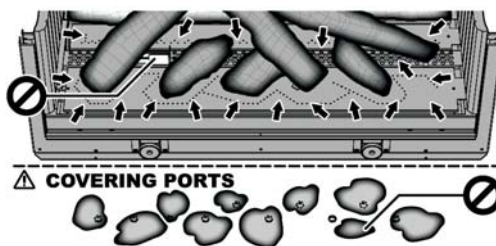

It is desirable that the gas jets are diffused by the granular burner media, as this will reduce any 'candling' effect of the flame, as well as enhance the flames look and the realistic log burning appearance of the heater. ⚠ DO NOT place granular material on top of the pilot or force any granular material into and or completely block any of the burner ports.

Time taken for complete ignition of both front and rear burners **MUST NOT** exceed 35 seconds. If complete ignition exceeds 35 seconds reposition granular media as per step 2 above and re-test.

B. Installation of Ceramic River Stones (Both Models)

The stone set for the RHFE-952ER consists of 30 stones of various size, colour, quantity and shape, of these there are 5 stones that have a central location slot ❶.

The stone set for the RHFE-1252ER consists of 40 stones of various size, colour, quantity and shape, of these there are 5 stones that have a central location slot ❶.

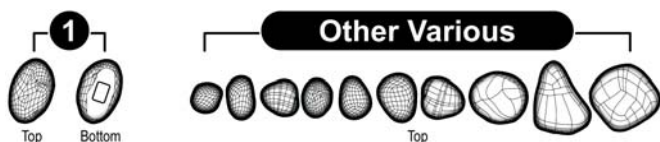

1. Place one of the slotted stones ❶ onto each of the five brackets located on the front burner, ensuring a random orientation of these stones will achieve the best visual appearance.
2. Place the remaining stone types evenly over the surface of both burners in a random manner, ensuring a random orientation of these stones will again achieve the best visual appearance.

The TOP VIEW image to the right may be used as an approximate guide to the stone placement.

3. Carefully place the supplied granular burner media in and around the stones. For the best flame effect carefully place the granular burner medium over and around the front and rear burner ports.

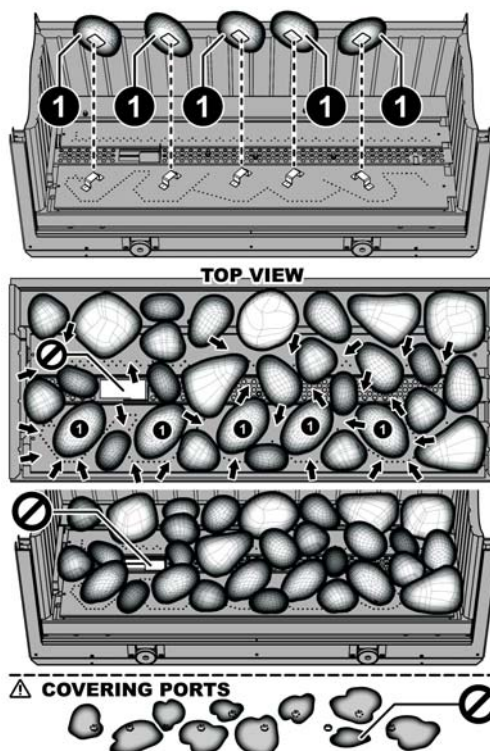

Note: Same install method used for both models, RHFE-952ER shown.



It is desirable that the gas jets are diffused by the granular burner media, as this will reduce any 'candling' effect of the flame as well as enhance the flames look.

⚠ DO NOT place granular material on top of the pilot or force any granular material into and or completely block any of the burner ports.

Time taken for complete ignition of both front and rear burners **MUST NOT** exceed 35 seconds. If complete ignition exceeds 35 seconds reposition granular media as per step 3 above and re-test.

Replacing Combustion Chamber Glass

1. Tilt the Combustion Chamber Glass **K** forward by about 10° and sit it onto the bottom supports of the Combustion Chamber frame and rotate back to vertical at the top.
2. Replace and **HAND TIGHTEN** the four retaining screws **J**, then back each of the screws off by a ¼ of a turn to ensure the combustion chamber glass retaining springs are engaged.

To test this gently pull the top of the glass frame forward and release, a correctly fitted the glass will spring firmly back into place and seal the combustion chamber.

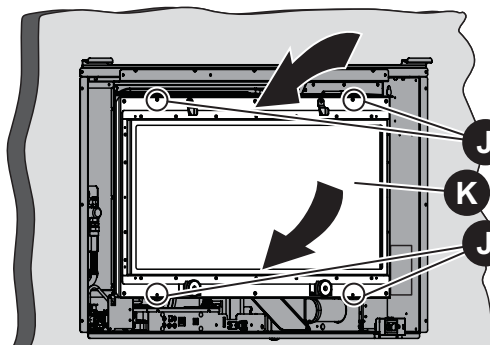

6. COMMISSIONING

Extended Flue

The gas pressures of the appliance are factory pre set for 'extended flue' installations (page 21 Options ②, ③, ④ and ⑤) and will normally not require adjustment and you may proceed to step 7).

Direct Flue

If the appliance is to be used with a 'direct' flue system (page 21 Option ①), then gas pressures will need to be adjusted in accordance with the commissioning instruction sheet **L** located in a plastic pouch inside the appliance at the bottom right.

When commissioning is complete check for full and correct operation of the appliance, and return the commissioning instruction sheet to its plastic pouch, proceed to step 7.

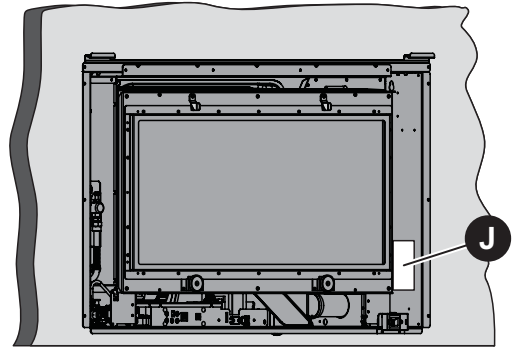

7. INSTALLING THE OUTER FASCIA PANEL

1. Remove but **DO NOT DISCARD** the two fascia retaining screws **M** shipped installed in the lower fascia mounting brackets **N** of the heater engine.

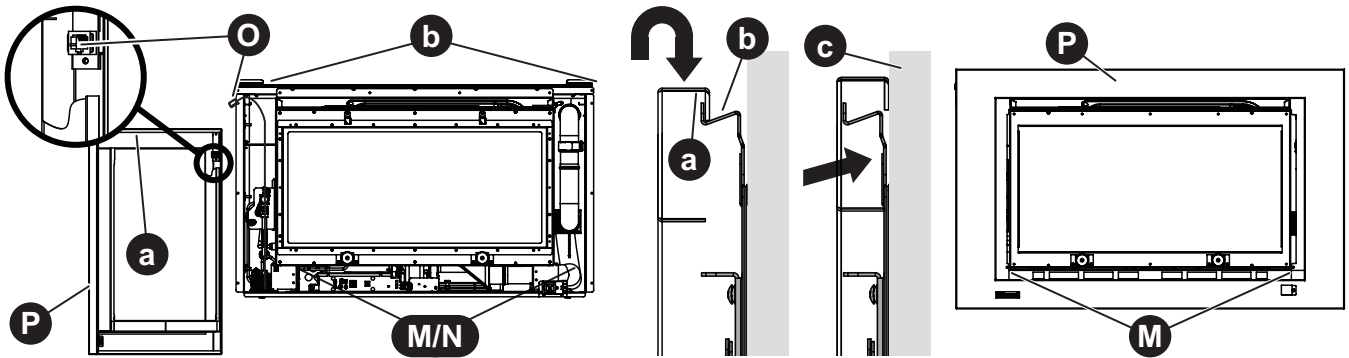

2. Position the fascia close to the heater engine and connect the RJ45 plug into the socket located on the inside top left of the fascia **O**, (this connects the push button control panel via a communications cable to the heater engine's control box).
3. Mount the outer fascia **P** to the engine by hooking the top inside fold of the outer fascia **a** over the tabs on the top lip of the engine body **b**, then push the outer fascia in towards the wall surface **c**. Secure the fascia to the heater engine with two retaining screws **M**.

8. INSTALLING THE INNER FASCIA PANEL

1. Mount the inner fascia **Q** to the engine by hooking the tabs of the inside top of the inner fascia **a** to the top lip of the combustion chamber frame **b**.

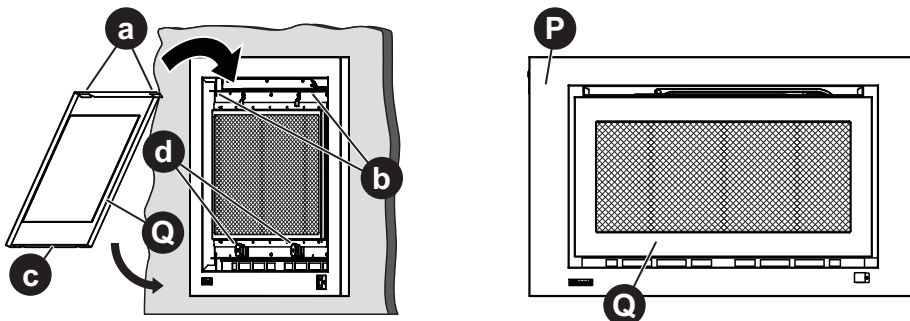

2. Rotate the bottom of the inner fascia **c** in towards the engine body allowing the magnets **d** to secure the inner fascia to the heater engine.

9. INSTALLATION AND COMMISSIONING CHECKLIST

- Complete the Installation Check List and the Installer details below.
- Instruct customer on the Rinnai RHFE-952ER / RHFE-1252ER Power Flued Flamefire operation.
- Ensure the customer understands the content of this manual.



Advise the customer that during the initial burning period of approximately 2 hours, some smoke and odour may be experienced. During this period the heater should be operated on ‘High’ and the space being heated should be well ventilated. It may take up to 20 minutes of operation for the logs to achieve their full flame pattern and glow.



The glass dress guard fitted to this appliance reduces the risk of fire and injury and no part of it should be permanently removed.

- For protection of young children or the infirm a secondary guard is required.
- Ensure this Operation and Installation manual is left with the customer.



Ensure the Customer understands that:

No part of this appliance should be permanently removed.

Paper or other material MUST NOT be burnt in this appliance.

Young children and the infirm should be supervised at all times.

10. FINAL CHECKLIST

(To be completed by certified Gas Installer)

	NO	/	YES
1. Appliance positioned in a suitable location? (clearances, combustible clearances, mantels & surrounds, etc.).	<input type="checkbox"/>		<input type="checkbox"/>
2. Is a Rinnai approved flue system installed & tested in accordance with the instructions?	<input type="checkbox"/>		<input type="checkbox"/>
3. Gas pressure checked and set?	<input type="checkbox"/>		<input type="checkbox"/>
4. Has the burner media been installed as per instructions?	<input type="checkbox"/>		<input type="checkbox"/>
5. Appliance tested for correct operation and to ensure no gas leaks?	<input type="checkbox"/>		<input type="checkbox"/>
6. Customer instructed on operating procedure and safety requirements?	<input type="checkbox"/>		<input type="checkbox"/>
7. Is the end-user fully aware of operating procedure?	<input type="checkbox"/>		<input type="checkbox"/>

WIRING DIAGRAM

Mark	Part
B	Burner
BL	Combustion Fan Motor
ER	Electrode
F	Fuse Electrical
FM	Convection Fan Motor
FR1-2	Flame Rod 1-2
L	Light
OH.TH 1-2	Over Heat Thermistor 1-2
PB	Pilot Burner
POV	Modulated Solenoid Valve
R.TH	Room Thermistor
RCR	Remote Control Circuit
SC	Speed control
SP	Sparker
SV1-4	Main Solenoid Valve 1-4
TF	Thermal Fuse
TR	Transformer

Mark	Colour
bk	black
bl	blue
gr/y	yellow-Green stripe
gy	grey
or	orange
pl	purple
r	red
w	white
y	yellow
p	pink
br	brown

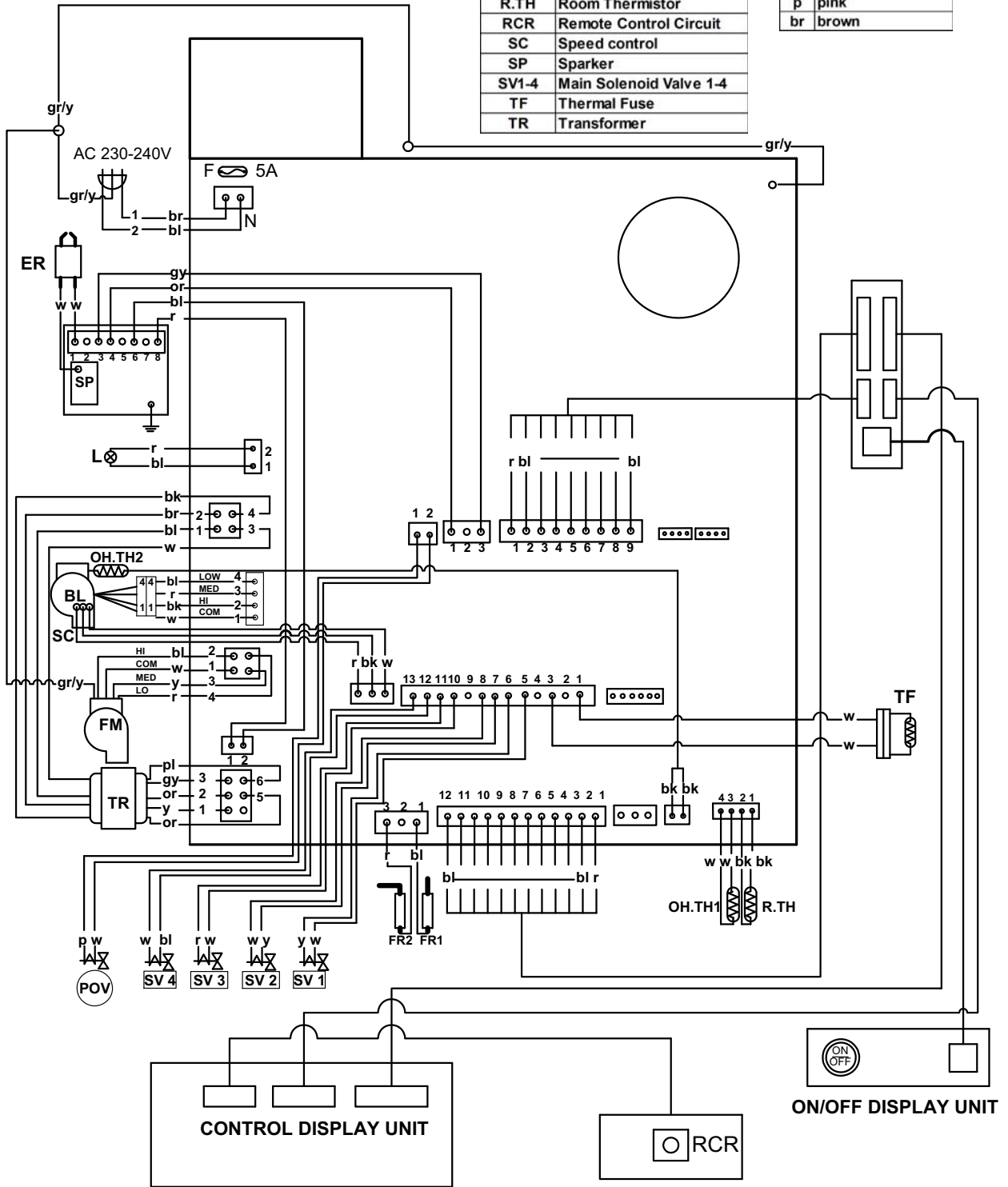

WIRING DIAGRAM UNI CONTROL MODEL 2
2 Burners and Combustion Fan
Issue 1

Rinnai

Rinnai Australia Pty. Ltd. ABN 74 005 138 769

Head Office

100 Atlantic Drive,
Keysborough VIC 3173

P.O. Box 460
Braeside, Victoria 3195

Rinnai has a Service and Spare Parts network with personnel who are fully trained and equipped to give the best service on your Rinnai appliance. If your appliance requires service, please call our National Help Line. Rinnai recommends that this appliance be serviced every 2 years.

National Help Line:

Phone: 1300 555 545* Fax: 1300 555 655*

**Cost of a local call higher from mobile or public phones.*

E-mail: enquiry@rinnai.com.au

For further information visit: www.rinnai.com.au